



MPA Analog positioning sensors

Precision and versatility up to 1007 millimeters

Universal in every respect: the MPA magnetic positioning sensor

For high-resolution position measurement and exact positioning in measuring ranges from 107 to 1,007 mm. The MPA magnetic positioning sensor is the versatile solution for demanding automation tasks.

Innovative, non-contact position detection

The MPA positioning sensor uses an array of Hall sensors to perform non-contact position detection of a wide variety of magnets. It uses an intelligent algorithm to adjust dynamically to the magnets during operation, so that the output signal is always linear and reproducible. The benefit: Correction for magnet aging and temperature fluctuations is performed dynamically. The position is provided with optimum resolution via an analog current or voltage output or IO-Link. The MPA positioning sensor is highly suitable for continuously detecting piston movements in pneumatic cylinders. It is also ideal for performing position measurements using external magnets.

Long measuring range for many applications

There is an MPA positioning sensor with the right length for every application, from 107 to 1,007 mm, in 36-mm steps. This makes it ideal for positioning pneumatic drives used for feeding, gripping, and measuring. The MPA makes it possible to optimize product processes and facilitates the implementation of quality assurance tasks. The MPA positioning sensor is also highly suitable for detecting the position of moving machine parts in applications such as monitoring the press-in depth of presses.

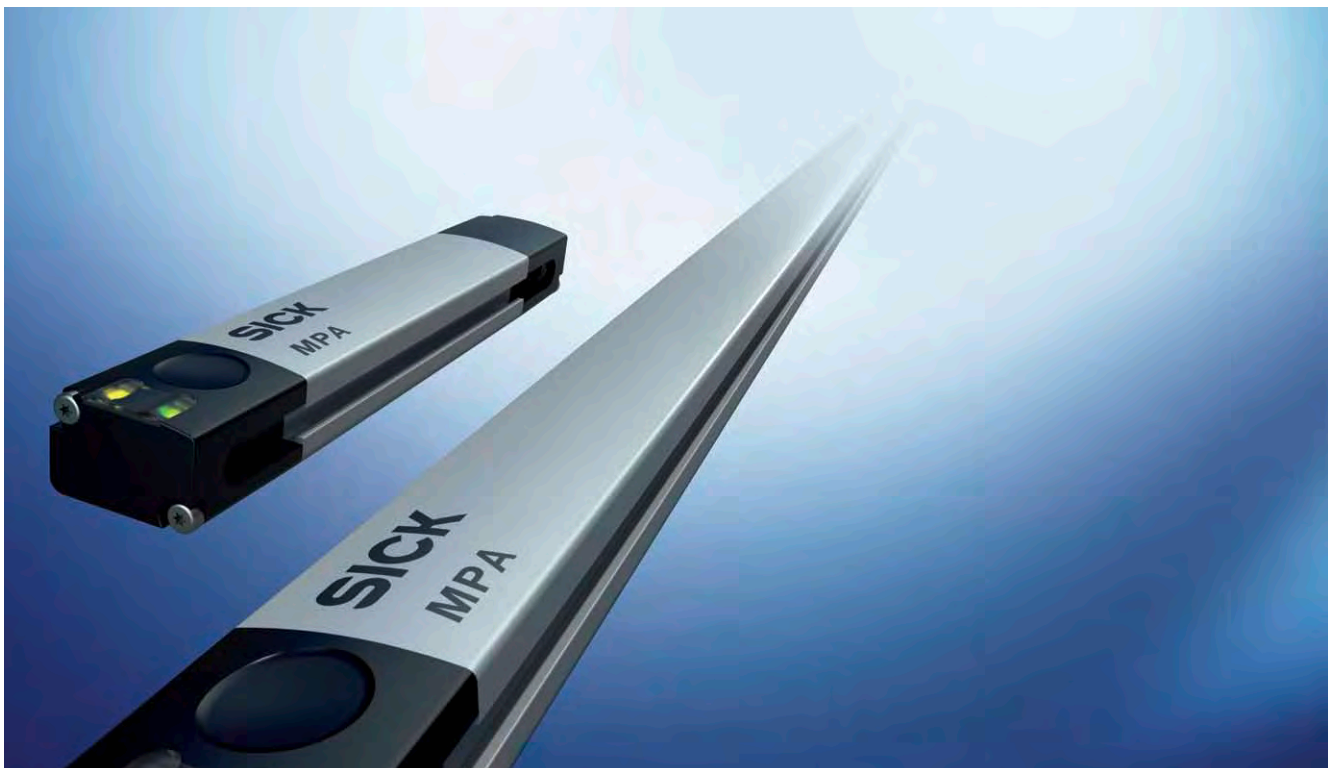

Highest precision – optimum values for resolution, linearity, and reproducibility

Position detection with high sampling rate

Precisely defined, repeatable output signals are an absolutely basic requirement for precision processes. In addition, the MPA positioning sensor provides these signal with a very high sampling rate of 1.15 ms.

Minimum blind zones ensure maximum flexibility

Since the MPA positioning sensor is only slightly longer than its measurement range, it provides high flexibility for a wide variety of applications. The minimum blind zones on the cable outlet and head allow problem-free installation even in extremely restricted areas.

Integrated IO-Link Technology

The MPA positioning sensor provides a current output between 4 and 20 mA, a voltage output between 0 and 10 V, and an IO-Link interface – all in once device. This means the highest level of flexibility in selecting the output signal and ease of matching to the higher-level controller.

IO-Link is a global universal communication standard for setting parameters and performing configuration for simple switching or analog sensors and actuators. IO-Link provides any automation system with easy access to completely integrated analog or digital sensor data.

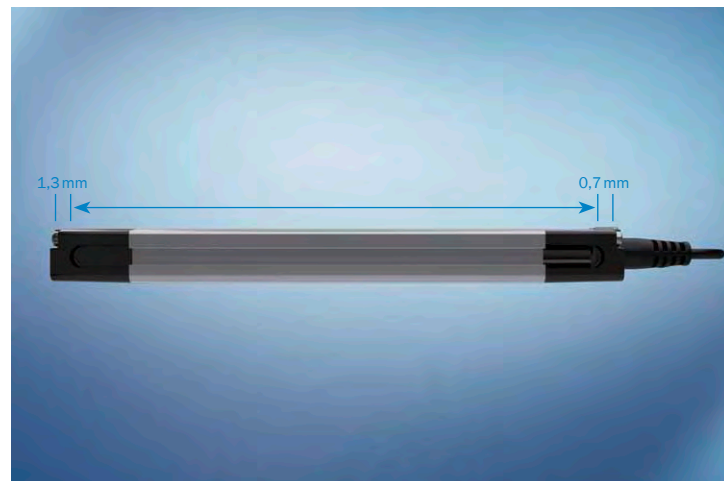

With minimum blind zones, the MPA position sensor can be used in a wide variety of applications (blind zones: cable outlet 0.7 mm, head 1.3 mm)



The rugged MPA positioning sensor has an IP 67 enclosure rating to provide reliable signals even in damp environments

Easy and effortless: commissioning and operation

Commissioning the MPA magnetic positioning sensor can be performed quickly and without the need for time-consuming integration. Setup using a teach pad, highly visible status LEDs, and extensive mounting accessories facilitate installation and commissioning.

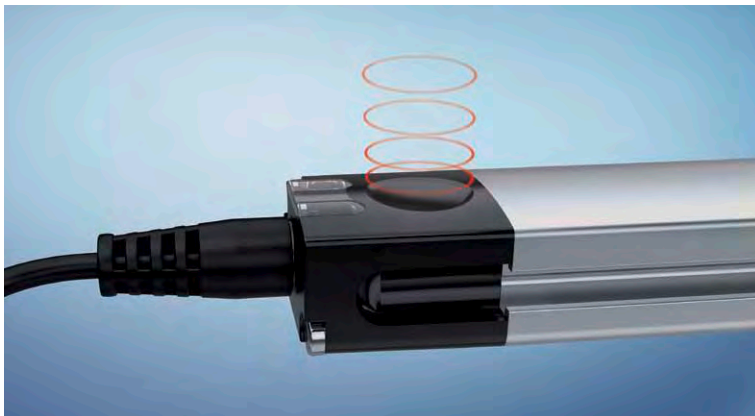

Easy to operate: the MPA positioning sensor's teach pad

A capacitive teach pad for ease of operation

The MPA has a capacitive teach pad to allow quick commissioning and flexible adjustment to modified tasks. Gentle finger pressure is all that is needed for selecting an output current between 4 and 20 mA, a voltage between 0 and 10V, or IO-Link, for optionally setting the measuring range, and for resetting to the factory settings. However, it is also safe from unintentional changes to the sensor settings.



Two bi-color LEDs provide high-visibility information during commissioning and operation about the current functional status of the sensor

Easy diagnosis with two bi-color LEDs

With a yellow LED for the „in range“ indication, a green LED and a blue LED for the selected signal output, and a red LED for fault indication, the MPA analog positioning sensor's bright LEDs provide direct information about the current functional status. The user-friendly LEDs also provide an indication if the magnetic field strength is insufficient.

Providing the highest stability for all applications: mounting accessories for the MPA positioning sensor

Mounting solutions for any application

An extensive range of mounting accessories are available for the versatile MPA positioning sensor. Customized adapters are available for mounting on roundbody cylinders, tie rod cylinders, cylinders with T-slots, and other cylinder types. Mounting brackets and external magnets are provided for other linear position measurement applications. In all cases, the sensor can be easily and securely mounted and equipped with matching connection technology.

Rugged and durable

A rugged, chemically resistant aluminum housing and cable kink protection protect the MPA positioning sensor from mechanical stresses. The aluminum housing has a capacitive, seamless teach pad to provide a high level of impermeability and moisture protection, and is the basis for its high IP 67 enclosure rating. And last but not least, the MPA positioning sensor is non-contact and is thus wear-free, ensuring an extremely long service life.



The mounting adapter for cylinders with tie rods makes mounting the MPA positioning sensor quick and safe

Precision and versatility up to 1007 millimeters



Product description

The MPA is a precision magnetic positioning sensor with analog output, offering an economical alternative to potentiometers or other displacement sensors. Firstly, MPA saves significant installation time compared to other measurement sensors. The MPA is available for 107 to 1007 mm measurement and

can be directly mounted on electrical and pneumatic drives. Also, MPA can be used with external magnets instead of actuators thanks to its universal housing with mounting adapters. An intuitive, capacitive Teach Pad as well as the 4-color LED display means the sensor can be commissioned quickly and easily.

At a glance

- Measured lengths from 107 to 1007 mm in 36 mm steps
- Output signals 4 to 20 mA as well as 0 to 10 V in a single sensor
- Can be mounted on various cylinders thanks to its universal housing with adapters, e.g., cylinders with T-slot, round and tie rod cylinders
- Linearity of 0.5 mm at a sample rate of 1.15 ms
- Accuracy of 0.03 % as well as reproducibility of 0.06 %
- IP 67 enclosure rating

Your benefits

- High flexibility through measuring ranges from 107 to 1007 mm
- Increased machine performance thanks to the sensor's minimal blind zone
- Saves time due to configurable start and end points via intelligent Teach Pad
- A rugged aluminum housing, the capacitive Teach Pad and the anti-kink cable guarantees a long operational lifetime of the sensor and reduces maintenance costs
- Time savings through simple commissioning and diagnostics thanks to a 4-color LED display
- Analog power, voltage signal and IO-Link in a single sensor reduces the range of variants and thereby lowers warehousing costs



Additional information

Detailed technical data 7

Ordering information 7

Dimensional drawing 9

Connection diagram 9

Accessories 10

→ www.mysick.com/en/MPA

For more information, just enter the link or scan the QR code and get direct access to technical data, CAD design models, operating instructions, software, application examples and much more.



Detailed technical data

Mechanics/electronics

Measuring range ¹⁾	107 mm ... 1,007 mm (depending on type)
Housing length	109 mm ... 1,009 mm (depending on type)
Supply voltage	15 V ... 30 V
EMC ²⁾	According to EN 60947-5-7
Load resistance, max. ³⁾	500 Ω
Min. load resistance ⁴⁾	2 Ω
Cable material	PUR
Reverse polarity protection	✓
Short-circuit protection	✓
Housing material	Aluminium
Housing cap material	PA strengthened
Enclosure rating	IP 65, IP 67
Analog output (voltage)	0 V ... 10 V
Analog output (current)	4 mA ... 20 mA
IO-Link	✓
Output indicator	✓
Linearity typ.	0.5 mm
Resolution typ. ⁵⁾	0.03 % FSR (≥ 0.06 mm)
Repeat accuracy typ ⁵⁾	0.06 % FSR (≥ 0.1 mm)
Sample rate	1.15 ms
Shock/vibration	30 g, 11 ms/10 Hz ... 55 Hz, 1 mm
Ambient operating temperature	-20 °C ... +70 °C

¹⁾ ± 1 mm.

²⁾ The analog measured value can deviate under transient conditions.

³⁾ Power output.

⁴⁾ Voltage output.

⁵⁾ FSR: Full Scale Range; max. measuring range.

Ordering information

- **Cylinder types with adapter:** Roundbody cylinder, Tie rod cylinder, T-slot
- **Output function:** analog, IO-Link

Measuring range ¹⁾	Connection	Model name	Part no.
107 mm	Cable, 2 m, PUR	MPA-107TSTU0	1059443
	Cable with plug M8, 4-pin, 300 mm, PUR	MPA-107TSTP0	1059442
143 mm	Cable with plug M8, 4-pin, 300 mm, PUR	MPA-143TSTP0	1059444
	Cable, 2 m, PUR	MPA-143TSTU0	1059445
179 mm	Cable with plug M8, 4-pin, 300 mm, PUR	MPA-179TSTP0	1059446
	Cable, 2 m, PUR	MPA-179TSTU0	1059447
215 mm	Cable with plug M8, 4-pin, 300 mm, PUR	MPA-215TSTP0	1059448
	Cable, 2 m, PUR	MPA-215TSTU0	1059449
251 mm	Cable with plug M8, 4-pin, 300 mm, PUR	MPA-251TSTP0	1059450
	Cable, 2 m, PUR	MPA-251TSTU0	1059451
287 mm	Cable, 2 m, PUR	MPA-287TSTU0	1059453
	Cable with plug M8, 4-pin, 300 mm, PUR	MPA-287TSTP0	1059452
323 mm	Cable, 2 m, PUR	MPA-323TSTU0	1059455
	Cable with plug M8, 4-pin, 300 mm, PUR	MPA-323TSTP0	1059454

Measuring range ¹⁾	Connection	Model name	Part no.
359 mm	Cable with plug M8, 4-pin, 300 mm, PUR	MPA-359TSTP0	1059456
	Cable, 2 m, PUR	MPA-359TSTU0	1059457
395 mm	Cable, 2 m, PUR	MPA-395TSTU0	1059459
	Cable with plug M8, 4-pin, 300 mm, PUR	MPA-395TSTP0	1059458
431 mm	Cable, 2 m, PUR	MPA-431TSTU0	1059461
	Cable with plug M8, 4-pin, 300 mm, PUR	MPA-431TSTP0	1059460
467 mm	Cable, 2 m, PUR	MPA-467TSTU0	1059463
	Cable with plug M8, 4-pin, 300 mm, PUR	MPA-467TSTP0	1059462
503 mm	Cable with plug M8, 4-pin, 300 mm, PUR	MPA-503TSTP0	1059464
	Cable, 2 m, PUR	MPA-503TSTU0	1059465
539 mm	Cable with plug M8, 4-pin, 300 mm, PUR	MPA-539TSTP0	1059466
575 mm	Cable with plug M8, 4-pin, 300 mm, PUR	MPA-575TSTP0	1059467
611 mm	Cable with plug M8, 4-pin, 300 mm, PUR	MPA-611TSTP0	1059468
647 mm	Cable with plug M8, 4-pin, 300 mm, PUR	MPA-647TSTP0	1059469
683 mm	Cable with plug M8, 4-pin, 300 mm, PUR	MPA-683TSTP0	1059470
719 mm	Cable with plug M8, 4-pin, 300 mm, PUR	MPA-719TSTP0	1059471
755 mm	Cable with plug M8, 4-pin, 300 mm, PUR	MPA-755TSTP0	1059472
791 mm	Cable with plug M8, 4-pin, 300 mm, PUR	MPA-791TSTP0	1059473
827 mm	Cable with plug M8, 4-pin, 300 mm, PUR	MPA-827TSTP0	1059474
863 mm	Cable with plug M8, 4-pin, 300 mm, PUR	MPA-863TSTP0	1059475
899 mm	Cable with plug M8, 4-pin, 300 mm, PUR	MPA-899TSTP0	1059476
935 mm	Cable with plug M8, 4-pin, 300 mm, PUR	MPA-935TSTP0	1059477
971 mm	Cable with plug M8, 4-pin, 300 mm, PUR	MPA-971TSTP0	1059478
1,007 mm	Cable with plug M8, 4-pin, 300 mm, PUR	MPA-1007TSTP0	1059479

¹⁾ ± 1 mm.

Dimensional drawing

dimensions in mm

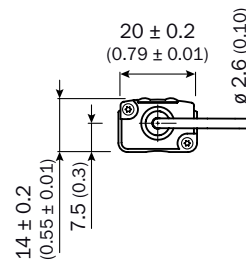
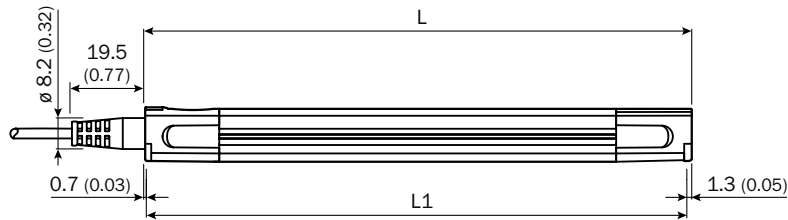
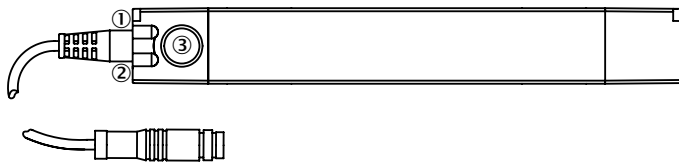

	Total length (L) mm	Measuring range (L1) mm		Total length (L) mm	Measuring range (L1) mm
MPA-107	109	107	MPA-575	577	575
MPA-143	145	143	MPA-611	613	611
MPA-179	181	179	MPA-647	649	647
MPA-215	217	215	MPA-683	685	683
MPA-251	253	251	MPA-719	721	719
MPA-287	289	287	MPA-755	757	755
MPA-323	325	323	MPA-791	793	791
MPA-359	361	359	MPA-827	829	827
MPA-395	397	395	MPA-863	865	863
MPA-431	433	431	MPA-899	901	899
MPA-467	469	467	MPA-935	937	935
MPA-503	505	503	MPA-971	973	971
MPA-539	541	539	MPA-1007	1,009	1,007

- ① Function signal indicator 1
- ② Function signal indicator 2
- ③ Teach-Pad

Connection diagram

Cd-263

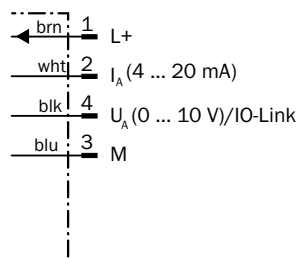

Accessories

Brackets for cylinder sensors

Accessory type	Model name	Part no.
For tie-rod cylinder (diameter tie-rod max. 18 mm)	BEF-KHWPZ1MPA	2065578
For T-slot cylinders	BEF-KHZA01MPA	2065575
For round body cylinders with diameter up to 85 mm	BEF-KHZR085MPA	2066626
For round body cylinders with diameter up to 135 mm	BEF-KHZR135MPA	2066627
For round body cylinders with diameter up to 210 mm	BEF-KHZR210MPA	2066628

BEF-WNL01MPA

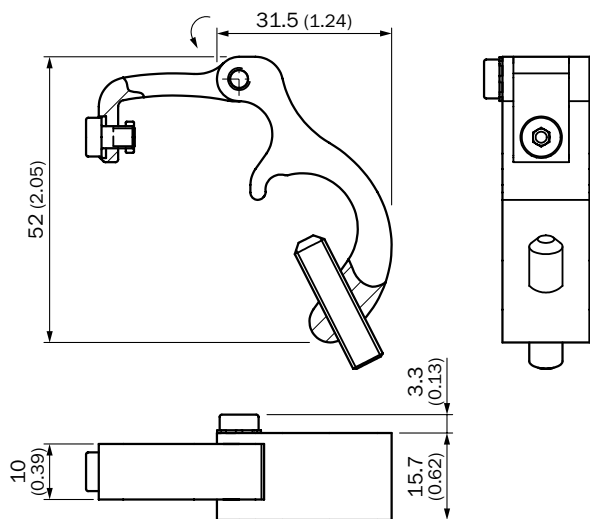

BEF-WNZ01MPA

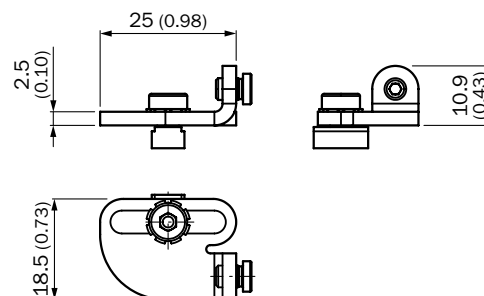

BEF-KHZR085MPA
BEF-KHZR135MPA
BEF-KHZR210MPA

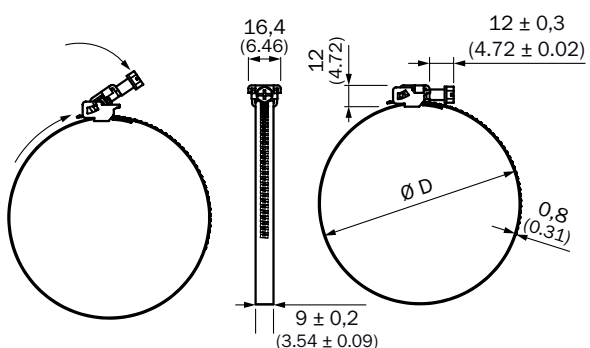

	Diameter (D) mm
BEF-KHZR085MPA	25 - 100
BEF-KHZR135MPA	25 - 150
BEF-KHZR210MPA	25 - 225

Magnets

Dimensions (L x W x H)	Model name	Part no.
Hard ferrite magnet, 15.2 mm x 3.2 mm x 6.0 mm	MAGNET	7901784

Mounting brackets/plates

Accessory type	Accessory type	Model name	Part no.
Mounting brackets	Bracket for low mounting	BEF-WNL01MPA	2065973
	Bracket for lateral mounting	BEF-WNZ01MPA	2065577

BEF-WNL01MPA

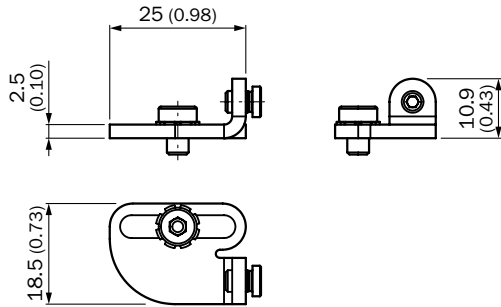

BEF-WNZ01MPA

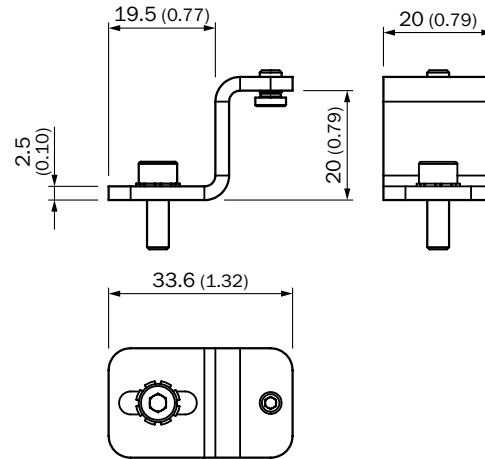

Search online quickly and safely with the SICK „Finders“

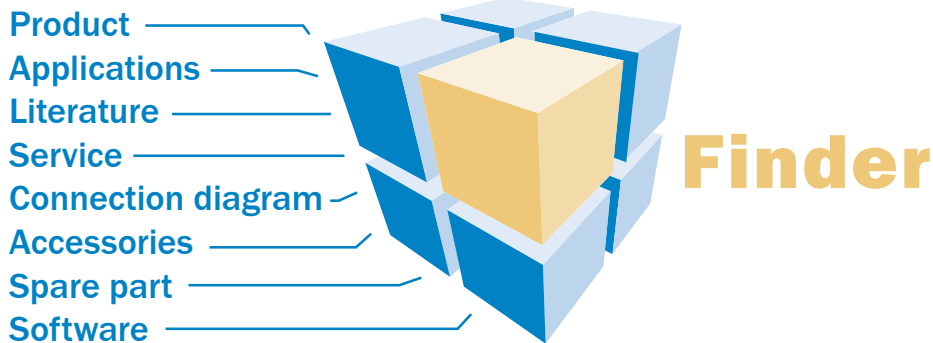

Product Finder: We can help you to quickly target the product that best matches your application.

Literature Finder: Go directly to the operating instructions, technical information, and other literature on all aspects of SICK products.

Applications Finder: Select the application description on the basis of the challenge posed, industrial sector, or product group.

These and other Finders at www.mysick.com

Efficiency – with SICK e-commerce tools

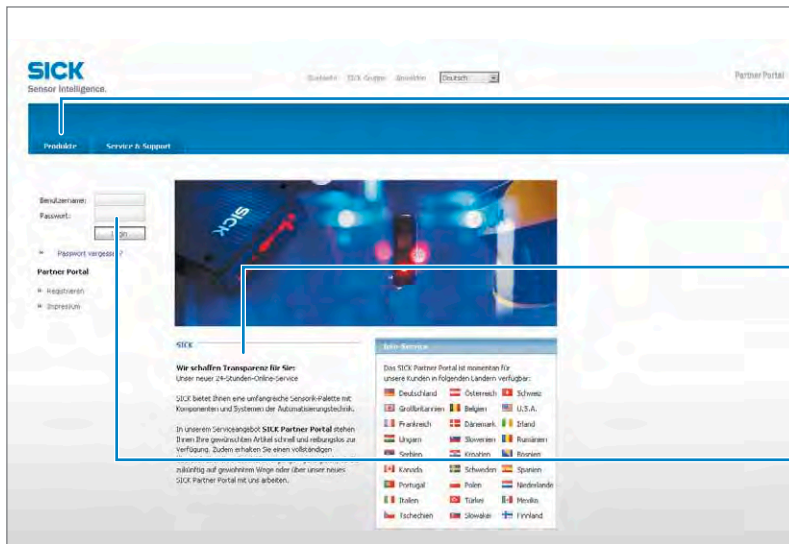

Clearly structured: You can find everything you need for your sensor planning under the menu items Products, Information, and My Account.

Available 24 hours a day: Regardless of where you are in the world or what you would like to know – everything is just a click away at www.mysick.com.

Safe: Your data is password-protected and only visible to you. With the individual user management, you define who can see what data and who can execute what actions.

Find out prices and availability

Determine the price and possible delivery date of your desired product simply and quickly at any time.

Order online

You can go through the ordering process in just a few steps.

Request or view a quote

You can have a quote generated online here. Every quote is confirmed to you via e-mail.

SICK at a glance

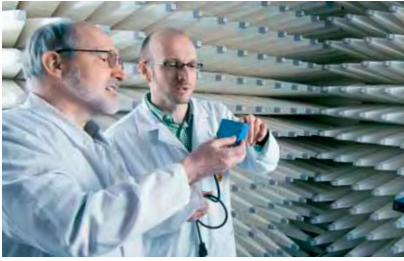

Leading technologies

With a staff of more than 5,000 and over 50 subsidiaries and representations worldwide, SICK is one of the leading and most successful manufacturers of sensor technology. The power of innovation and solution competency have made SICK the global market leader. No matter what the project and industry may be, talking with an expert from SICK will provide you with an ideal basis for your plans – there is no need to settle for anything less than the best.



Unique product range

- Non-contact detecting, counting, classifying, positioning and measuring of any type of object or media
- Accident and operator protection with sensors, safety software and services
- Automatic identification with bar code and RFID readers
- Laser measurement technology for detecting the volume, position and contour of people and objects
- Complete system solutions for analysis and flow measurement of gases and liquids



Comprehensive services

- SICK LifeTime Services – for safety and productivity
- Application centers in Europe, Asia and North America for the development of system solutions under real-world conditions
- E-Business Partner Portal www.mysick.com – price and availability of products, requests for quotation and online orders

Worldwide presence with subsidiaries in the following countries:

Australia
Belgium/Luxembourg
Brasil
Česká Republika
Canada
China
Danmark
Deutschland
España
France
Great Britain
India
Israel
Italia
Japan

México
Nederland
Norge
Österreich
Polska
România
Russia
Schweiz
Singapore
Slovenija
South Africa
South Korea
Suomi
Sverige
Taiwan
Türkiye
United Arab Emirates
USA

Please find detailed addresses and additional representatives and agencies in all major industrial nations at www.sick.com