

100 Watt Internal Fitting RSF30

The RSF30 series is a range of higher power side entry, internally fitted devices. These may be used for directly switching some small loads of less than 100VA. Mounting of this series requires access to the inside of the tank. They are manufactured in Nylon or Polypropylene, with a choice of gasket materials, to suit most commonly used liquids.

The switch action may be reversed by rotating the device through 180°.

- 100W contacts
- Rugged design
- Reliable reed switch contacts
- WRAS approval
- Many variants are UL recognised components file number E171218

Technical Specifications	RSF33	RSF34
Material	Nylon	Polypropylene
Colour	Black	Opaque
Temp. Range °C	-20 / +75	-20 / +100
°F	-4 / +167	-4 / +212
Min. Fluid S.G.	0.8	0.8
Must Close Level (S.G.=1)	20mm	23mm
Must Open Level (S.G.=1)	47mm	52mm

Electrical Specifications	
Contact Form	N/O (N/C)
Switching Power Max VA	100
Switching Voltage AC Max	240
Switching Voltage DC Max	120
Switching Current Max. A	5

All ratings are for resistive load only.

Standard Parts	Material	Leadouts	Gaskets
RSF33W100RC	Nylon	1.0m PVC 16/0.2 UL approved	Nitrile
RSF34W100RF	Polypropylene	1.0m PVC 16/0.2 UL approved	Nitrile

Custom versions can be made for particular applications. Please contact Cynergy3 with your requirements.



Outline Dimensions

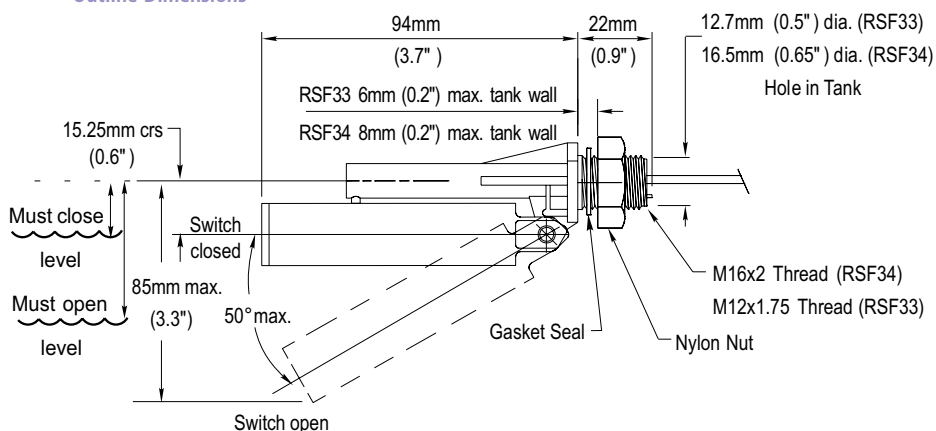

Contact us in **USA.**

t: (866) 258 5057 f: (619) 690 7432

e: sales@cynergy3.com w: www.cynergy3.com