



Distance sensors

## WTA 24: Distance measurement and object detection in one device



The WTA 24 with its compact metal housing is immune to impacts, vibrations and other disturbances. This and numerous other features make this device suitable for a large number of applications such as profile measurement, the detection of coil diameters, level monitoring, for positioning tasks in warehousing and handling systems and min./max. regulation with combined switching points.

**N**on-contact distance measurement and object detection – the WTA 24 photoelectric proximity switch combines both these functions. The sensor, available in three versions, covers scanning distances ranging from 100 to 3,000 mm. The triangulation principle is used to detect the presence and position of an object. The presence of an object is signalled via the digital device outputs; continuous distance values are further processed by means of the analogue interface.

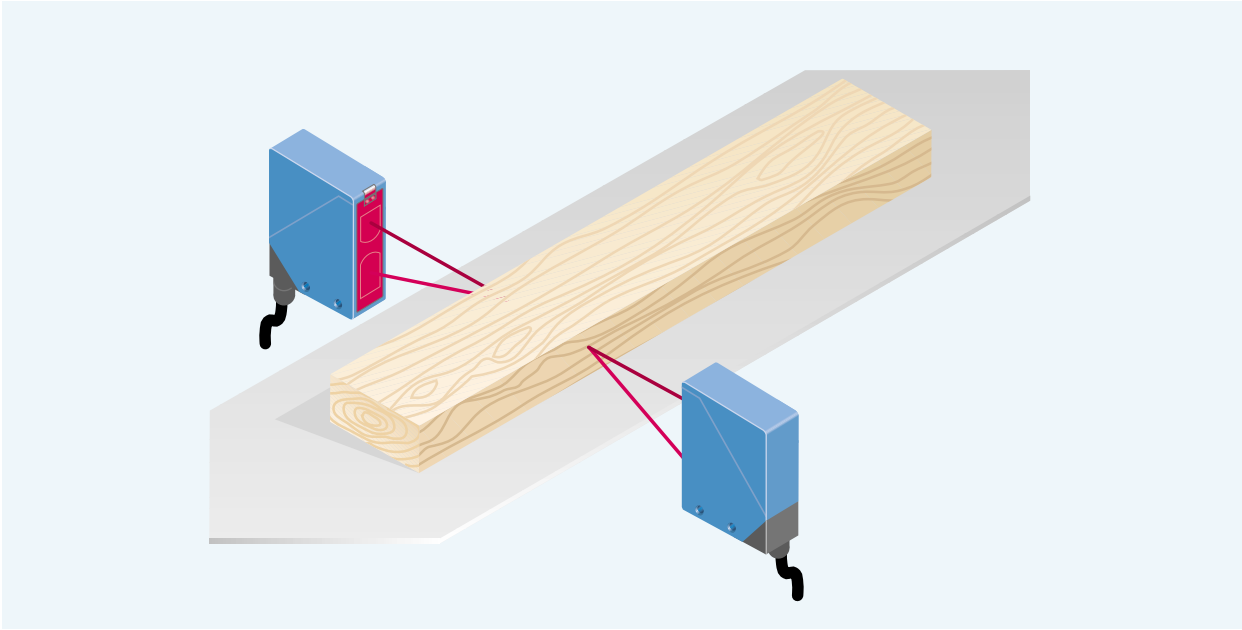

◀ On circular cross-cut saws, the width is measured continuously while the boards are automatically advanced. WTA 24 sensors see to this reliably.

▶ On circular cross-cut saws, the width is measured continuously while the boards are automatically advanced.

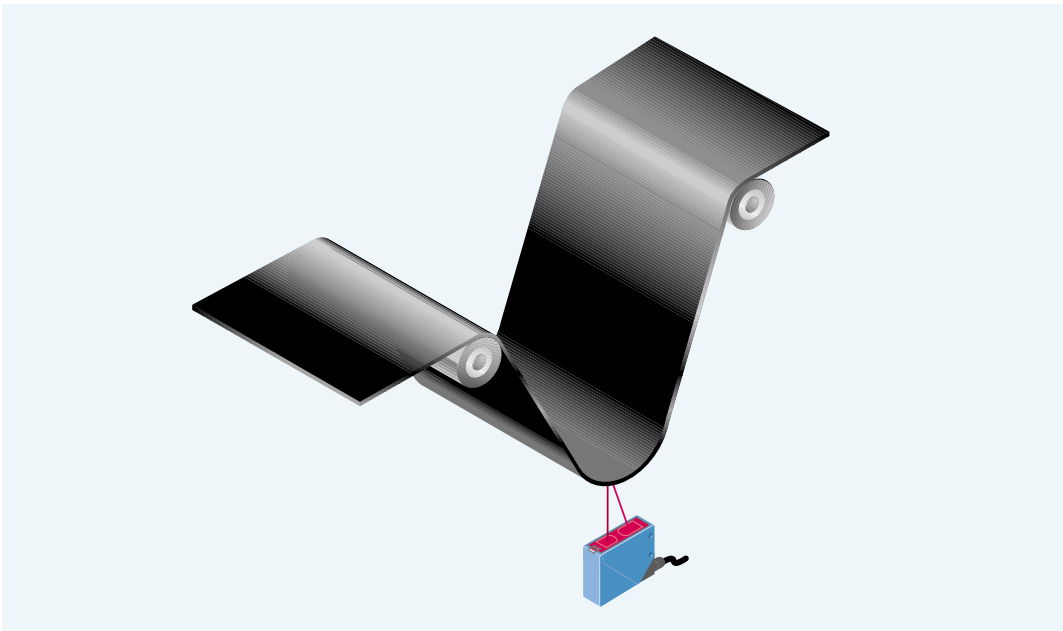

◀ In continuous tyre production, supply loops regulate web tension and, therefore, the tensile force in the material. The WTA 24 ensures that the loops are fed evenly.

**Scanning distance**  
100...3000 mm

Photoelectric proximity switches

- Analogue + digital output
- High resolution
- Switching outputs adjustable using simple teach-in
- Compact housing
- Insensitive to ambient light

**Dimensional drawing**

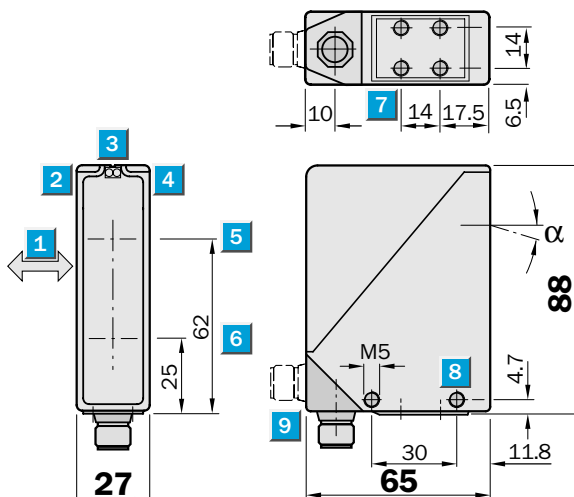

**Adjustments possible**

All types

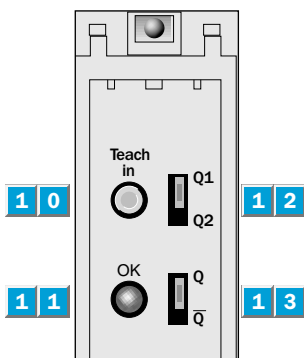

- 1 Standard direction of object being scanned
- 2 Output Q<sub>2</sub> function indicator
- 3 Alignment sight
- 4 Output Q<sub>1</sub> function indicator
- 5 Centre of transmitter's optical axis
- 6 Centre of receiver's optical axis
- 7 M5 threaded mounting hole, 6 mm deep
- 8 M5 threaded mounting hole
- 9 Rotatable plug
- 1 0 "Teach- in" programming switch
- 1 1 "Teach- in" function indicator
- 1 2 "Q<sub>1</sub>/Q<sub>2</sub>" program switch
- 1 3 "Q/Q" program switch

**Adjustment instructions**

- Programming the switching outputs:
1. Move "Q<sub>1</sub>/Q<sub>2</sub>" switch to the switching output to be programmed. Move "Q/Q" switch to the desired switching mode.
  2. Place object at the required switching distance.
  3. Press "Teach- in" key. "OK" indicator illuminates when the switching limit has been saved to the memory.
  4. Repeat steps 1/2/3 for the second switching output.
  5. The device is ready for operation.

**Connection type**

All types

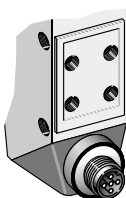

5-pin, M 12

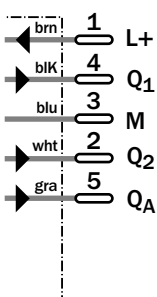

Accessories	page
Cable receptacles	496
Mounting brackets	510
Cooling plates	556
Weather covers	556



Technical Data		WTA 24-P	5201	5401	5501	5201 S 04						
<b>Light source<sup>1)</sup>, light type</b>	LED, infrared light											
<b>Supply voltage V<sub>S</sub></b>	12 ... 30 V DC <sup>2)</sup>											
Ripple	< 5 V <sub>SS</sub> <sup>3)</sup>											
Current consumption	< 100 mA <sup>4)</sup>											
<b>Switching outputs</b>												
Q <sub>1</sub> , Q <sub>2</sub>	PNP, reversible											
Output voltage	HIGH = V <sub>S</sub> - < 2 V / LOW = < 2 V											
Output current I <sub>A</sub> max.	100 mA											
Response time <sup>5)</sup>	5 ms											
Max. switching frequency <sup>6)</sup>	100 Hz											
Response time <sup>5)</sup>	50 ms											
Max. switching frequency <sup>6)</sup>	10 Hz											
Response time <sup>5)</sup>	100 ms											
Max. switching frequency <sup>6)</sup>	5 Hz											
<b>Analogue output<sup>7) 8)</sup></b>	4 ... 20 mA											
<b>Connection type</b>	Plug											
<b>VDE protection class<sup>9)</sup></b>	□											
<b>Circuit protection<sup>10)</sup></b>	A, B, C											
<b>Enclosure rating</b>	IP 67											
<b>Ambient temperature T<sub>A</sub><sup>8)</sup></b>	Operation - 10 °C...+ 55 °C Storage - 25 °C...+ 75 °C											
<b>Shock load</b>	To IEC 68											
<b>Temperature drift</b>	0.2 %/K											

- 1) Average service life 100,000 h at T<sub>A</sub> = + 25 °C
- 2) Limit values
- 3) May not exceed or fall short of V<sub>S</sub> tolerances
- 4) Without load
- 5) Signal transit time with resistive load
- 6) Object 50 : 50
- 7) In capture range 3 or 21 mA
- 8) R = 0...500 Ω
- 9) Reference voltage 50 VDC
- 10) A = V<sub>S</sub> connections reverse-polarity protected  
B = Inputs Q<sub>1</sub> and Q<sub>2</sub> short-circuit protected  
C = Interference pulse suppression

Measurement range, reproducibility and accuracy									
WTA 24-	P 5201		P 5401		P 5501		P 5201 S04		
<b>Measurement range</b>	250...350 mm		600...1200 mm		1000...3000 mm		100...500 mm		
<b>Capture range</b>	200...250 mm		400...600 mm		500...1000 mm		80...100 mm		
Light spot diameter (90 % core light)	4...8 mm		15...30 mm		20...50 mm		8...12 mm		
Angle of dispersion α	7°		2°		0.5°		7°		
<b>Reproducibility</b> (relative to measured value, object 100 x 100 mm, ambient surroundings remain constant)	White (90 %)	1.0 %	White (90 %)	1.5 %	White (90 %)	4.0 %	White (90 %)	1.0 %	
	Grey (18 %)	1.0 %	Grey (18 %)	2.5 %	Grey (18 %)	10.0 %	Black (6 %)	2.0 %	
	Black (6 %)	1.5 %	Black (6 %) <sup>1)</sup>	4.0 %	Black (6 %) <sup>2)</sup>	8.0 %			
<b>Accuracy</b> (relative to measured value, object 100 x 100 mm, ambient surroundings remain constant)	blanc (90 %)	1.5 %	blanc (90 %)	3.0 %	blanc (90 %)	5.5 %	White (90 %)	6.5 %	
	Grey (18 %)	2.0 %	Grey (18 %)	5.0 %	Grey (18 %)	13.0 %	Grey (18 %)	10.5 %	
	Black (6 %)	4.0 %	Black (6 %) <sup>1)</sup>	8.0 %	Black (6 %) <sup>2)</sup>	10.0 %	Black (6 %)	11.5 %	

- 1) up to 1000 mm
- 2) up to 2000 mm

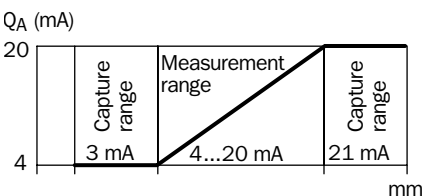

Order information	
Type	Part no.
WTA 24-P 5201	1 011 504
WTA 24-P 5401	1 011 505
WTA 24-P 5501	1 011 515
WTA 24-P 5201 S04	1 015 804